

Hexagon Nuts
Metric Thread
Type g

DIN
555

Sechskantmuttern; Metrisches Gewinde; Ausführung g

The dimensions of the hexagon nuts according to this Standard correspond with those indicated in the ISO Recommendation ISO/R 272-1968 published by the International Organization for Standardization (ISO).

Dimensions in mm

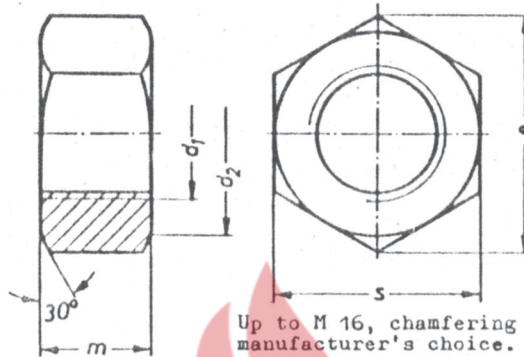

Up to M 16, chamfering on one side permissible at manufacturer's choice.

Designation of a hexagon nut with thread $d_1 = M 10$:

Hexagon nut M 10 DIN 555

d_1	d_2 min.	e min.	m	s	Weight (7,85 kg/dm ³) kg/1000 pieces ≈	d_1	$d_2^{2)}$ min.	e min.	m	s	Weight (7,85 kg/dm ³) kg/1000 pieces ≈
M 5	7,2	8,63	4	8	1,11	(M 39)	54	66,44	31	60	472
M 6	9	10,89	5	10	2,32	M 42	62	72,09	34	65	610
M 8	11,7	14,20	6,5	13	4,62	(M 45)	66	77,74	36	70	750
M 10	15,3	18,72	8	17	10,9	M 48	71	83,39	38	75	924
M 12	17,1	20,88	10	19	15,9	(M 52)	76	89,04	42	80	1130
M 16	21,6	26,17	13	24	30,8	M 56	81	94,47	45	85	1350
M 20	27	32,95	16	30	60,3	(M 60)	85	100,12	48	90	1600
M 22 ¹⁾	28,8	35,03	18	32	80,2	M 64	90	105,77	51	95	1880
M 24	32,4	39,55	19	36	103	M 72×6	100	117,07	58	105	2520
(M 27)	36,9	45,20	22	41	154	M 80×6	110	128,37	64	115	3260
M 30	41,4	50,85	24	46	216	M 90×6	125	145,09	72	130	4680
(M 33)	45	55,37	26	50	271	M 100×6	140	162,04	80	145	6340
M 36	49,5	60,79	29	55	369	—	—	—	—	—	—

Bracketed sizes should be avoided wherever possible.

Technical conditions of delivery according to DIN 267

Strength category or material: 5 according to DIN 267 Part 4

Type: g according to DIN 267 Part 2

If surface protection is desired, the designation shall be augmented according to DIN 267 Part 9 or Part 10*).

*) At present still circulating as draft

1) For steel construction only

2) For sizes M 42 upwards, d_2 is an approximate measurement only.

No guarantee can be given in respect of this translation
In all cases the latest German-language version of this standard shall be taken as authoritative

Nachdruck, auch auszugsweise, nur mit Genehmigung des DIN Deutsches Institut für Normung e. V., Berlin 30, gestattet.

Translation
Fachtechnisches Übersetzungsinstitut
Henry G. Freeman, Düsseldorf